



INNOVA

Qingdao Innova Bio-Meditech Co., Ltd.

Add.: No. 176 Jufeng Road, 266199, Qingdao, China

Tel.: +86 532 8789 0634

Email: info@innobiomed.com

Web: www.innovabiomed.com

Laboratory Scale Freeze Dryer Pilot Scale Lyophilizer



About us

Innova Bio-Meditech is one of the professional solution provider of laboratory and medical devices. Firmly committed to our mission of "sharing innovative bio-meditech solutions with the world", we are dedicated to innovation in the fields of Biology Project, Life Science, Pharmacy Industry and Medical Treatment.

Innova Bio-Meditech possesses a sound distribution and service network with business partners in North and Latin America, Europe, Africa and Asia-Pacific etc. We have built up a well established R&D, manufacture network with 3 centers in Qingdao, Shanghai and Suzhou. Inspired by the needs of our customers, we adopt advanced technologies and transform them into accessible innovation. This means constant effort and research, in order to more fully understand the developments of the market, INNOVA produce constantly upgraded product ranges by adding new products year after year.

The passion for science



Contents

Advantages of Freeze Drying	1
Configuration-Laboratory Scale	2
<i>Vacuum Chamber</i>	3
<i>PLC Controller</i>	4
<i>Ice Condenser Chamber</i>	4
<i>Compressor and Condenser</i>	4
Configuration-Pilot Scale	5
Laboratory Scale - Benchtop	7
<i>Technical Parameter</i>	8
Laboratory Scale - Console(12 type)	9
<i>Technical Parameter</i>	10
Laboratory Scale - Console(18 type)	11
<i>Technical Parameter</i>	12
Model Selection	13
Pilot Scale - Benchtop & Floor Stand	15
<i>Technical Parameter</i>	16
Optional Accessories	19

Typical Applications

Our freeze dryers are suitable for a wide range of applications

- Preserving the product characteristics of the original substances.
- Preserving the original form (animal preparations, archaeological objects or flowers).
- Conditioning the material (freeze-dried fruit).
- Chemical analyses (trace element analyses of foods, sludge or soil).

Advantages of Freeze Drying

- Protein will not be denatured.

Freeze-drying is carried out at low temperature, for many heat-sensitive substances such as proteins and microorganisms will not denature or lose biological activity.

- Low temperature non-volatile.

When drying at low temperature, the loss of some volatile components in the substance is very small, which is suitable for drying chemical products, medicines and foods.

- Keep the original structure.

Since it is dried in a frozen state, the volume is almost unchanged, the original structure will be maintained.

- Fast reconstitution with water.

The dried material is loose and porous, in the form of sponge, after adding water, it dissolves quickly and restores its original properties.

- Powder non-oxidizing.

Since drying takes place under vacuum with very little oxygen, so oxidizable substances are protected.

- No deterioration after dehydration.

Drying can remove more than 95% - 99% of the water, so after drying, the samples can be stored for a long time without deterioration.

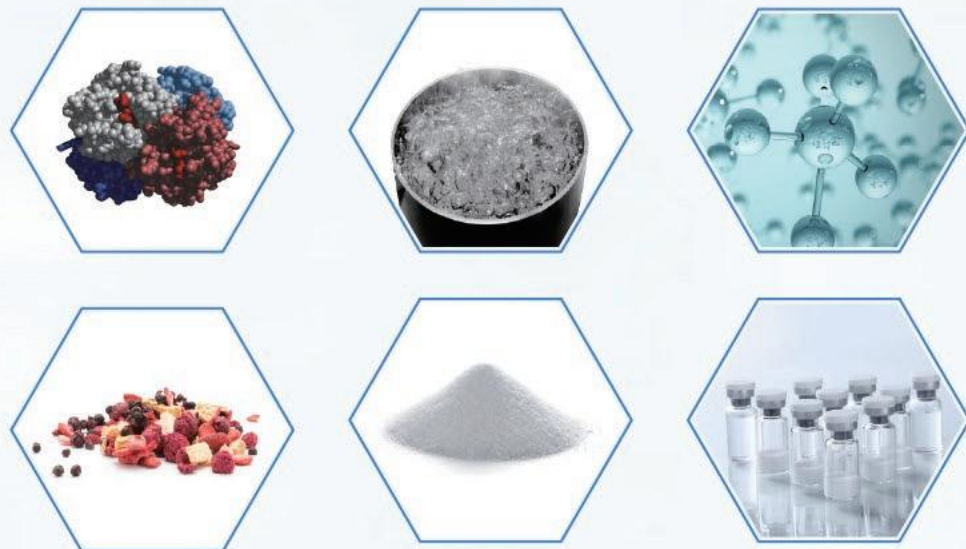

Configuration - Laboratory Scale



- | | |
|------------------------------|-------------------------------|
| 1 Vacuum chamber | 5 Ice condenser chamber |
| 2 Shelf with sensor PT 100 | 6 Vacuum pump connection port |
| 3 Stainless steel countertop | 7 Compressor and condenser |
| 4 Touch screen | |

Vacuum Chamber



How to Pre-freezing

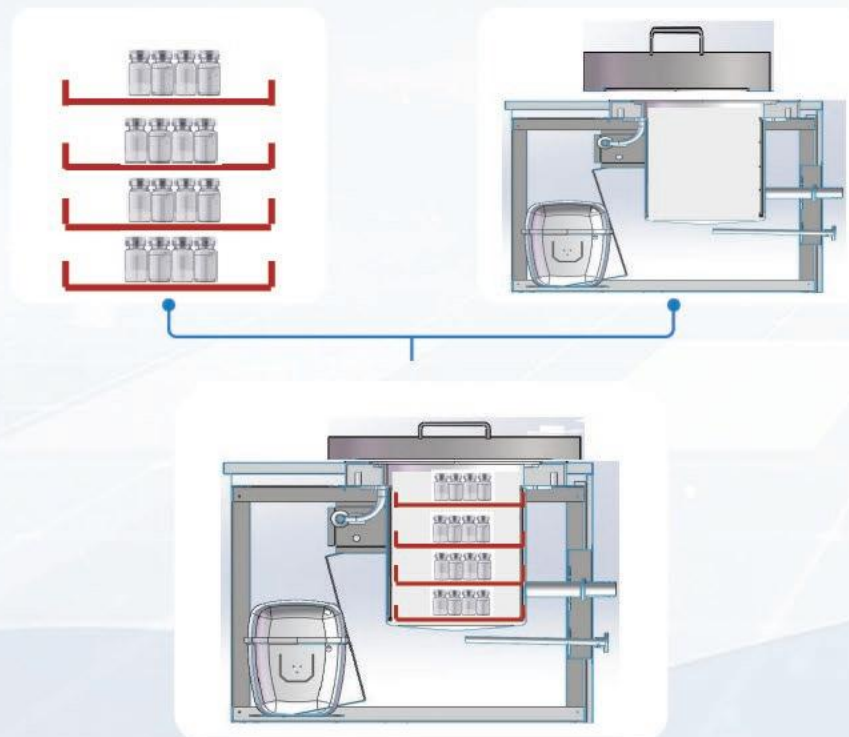

PLC Controller



Customized freeze drying process

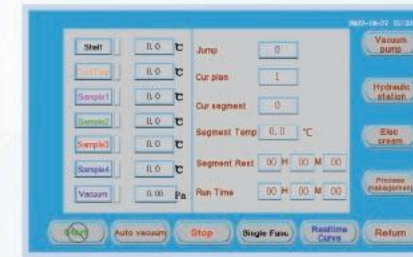

Main interface



Curve data

Ice Condenser Chamber

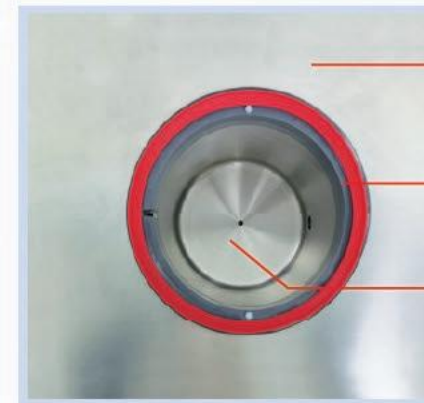

The countertop is stainless steel, corrosion resistance.

Wide mouth, easy to put the samples to pre-freezing.

Bottom with rounded corner design, easy to clean.

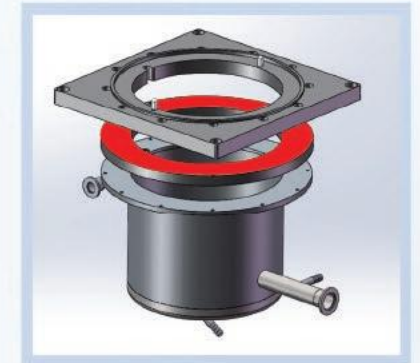

Thermal insulation

Compressor and Condenser

- -60 °C ice condenser chamber, at 25 °C ambient temperature 25 °C → -60 °C : 30 minutes.
- -80 °C ice condenser chamber, at 25 °C ambient temperature 25 °C → -80 °C : 30 minutes.
- The refrigerant is HCFC/CFC free.



Configuration - Pilot Scale

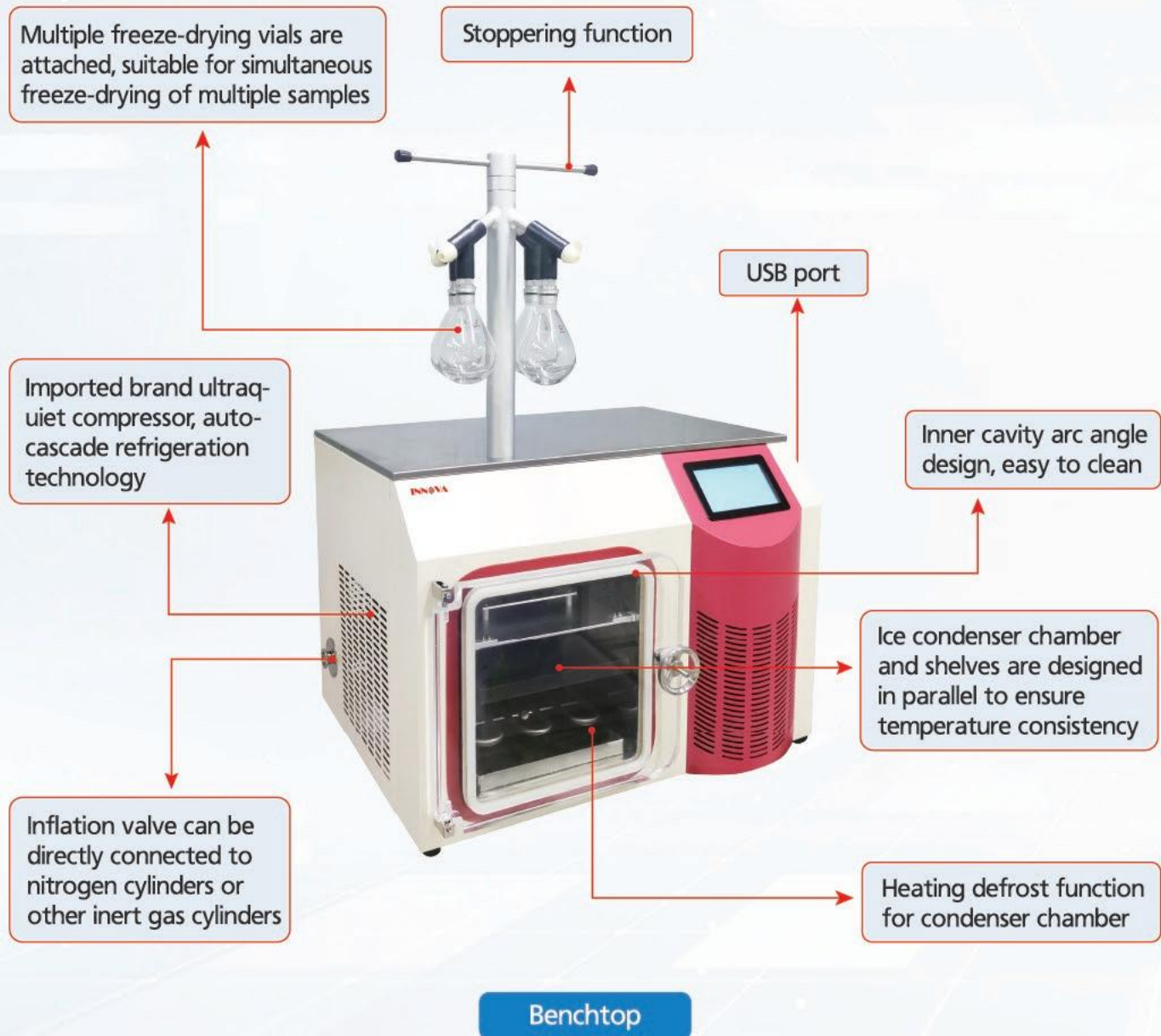

Configuration - Pilot Scale



- ① T type hydraulic rod
- ② PLC controller
- ③ Drying chamber (freezing and drying)
- ④ Sensor PT 100
- ⑤ Dust cover
- ⑥ Acrylic lass door
- ⑦ Condenser chamber
- ⑧ Vacuum tube
- ⑨ Material loading shelf

Laboratory Scale - Benchtop

Classic INOFD-10SU; INOFD-10TU; INOFD-10PU; INOFD-10PTU



INOFD-10SU



INOFD-10TU



INOFD-10PU



INOFD-10PTU

Technical Parameter

Model	INOFD-10SU	INOFD-10TU	INOFD-10PU	INOFD-10PTU
Basic information				
Type	Standard chamber	Stoppering chamber	Standard chamber with 8 port manifold	Stoppering chamber with 8 port manifold
Final condenser temp (°C)	-60	-60	-60	-60
Vacuum degree (Pa)	<10	<10	<10	<10
Condenser volume (L)	6.5	6.5	6.5	6.5
Freeze drying area (m ²)	0.12 or 0.18	0.09	0.12 or 0.18	0.09
Water condenser capacity (Kg/24h)	3	3	3	3
Qty of shelf	4 or 6*	3	4 or 6*	3
Material loading capacity/shelf (mL)	300	300	300	300
Material loading capacity (mL)	1200 or 1800	900	1200 or 1800	900
Manifold	/	/	8 pieces	8 pieces
USB interface	Y	Y	Y	Y
Drying chamber (standard)	Transparent acrylic			
Vacuum pump	Standard model: 2XZ-2**, Speed: 2L/S			
Control system	Microprocessor, touch screen			
Ultimate vacuum (Pa)	Economic: 1 Classic: 0.6			
Noise (dB)	<66			
Electrical requirement				
Electrical voltage	220V			
Electrical frequency	50Hz, 60Hz			
Power (Kw)	0.85			
Size information				
Condenser chamber dimension (φ×Hmm)	215×190			
Sample tray dimension (φ×Hmm)	200×20			
Sample shelf dimension (φ×Hmm)	210×365	234×518	210×365	234×518
Sample Shelf distance average (Hmm)	76 or 50***	70	76 or 50***	70
Host size (WxDxHmm)	600×540×374			
Vacuum hood dimension (upperφ/lowerφ×Hmm)	260/240×450			
Exterior dimension (WxDxHmm)	600×540×820	600×540×880	600×540×820	600×540×880
Host net weight (Kg)	46			
Package information				
Host package (WxDxHmm)	670×700×560			
Vacuum hood package (WxDxHmm)	410×410×640			
Vacuum pump package (WxDxHmm)	220×580×370			
Weight (Kg)	110			

*Optional 6 shelves with additional cost, with 0.18m² freeze drying area, and 1800ml material loading capacity.

**For customized vacuum pump, please see page 19 optional accessories for more details.

***50 mm for 6 shelves.

Laboratory Scale - Console

Classic INOFD-12SU; INOFD-12TU; INOFD-12PU; INOFD-12PTU

Premium INOFD-12SUP; INOFD-12TUP; INOFD-12PUP; INOFD-12PTUP



INOFD-12SU
INOFD-12SUP



INOFD-12TU
INOFD-12TUP



INOFD-12PU
INOFD-12PUP



INOFD-12PTU
INOFD-12PTUP

Technical Parameter

Model	INOFD-12SU INOFD-12SUP	INOFD-12TU INOFD-12TUP	INOFD-12PU INOFD-12PUP	INOFD-12PTU INOFD-12PTUP
Basic information				
Type	Standard chamber	Stoppering chamber	Standard chamber with 8 port manifold	Stoppering chamber with 8 port manifold
Final condenser temp (°C)	-60 or -80	-60 or -80	-60 or -80	-60 or -80
Vacuum degree (Pa)	<10	<10	<10	<10
Condenser volume (L)	9.5	9.5	9.5	9.5
Freeze drying area (m ²)	0.12 or 0.18	0.09	0.12 or 0.18	0.09
Water condenser capacity (Kg/24h)	4	4	4	4
Qty of shelf	4 or 6*	3	4 or 6*	3
Material loading capacity/shelf (mL)	300	300	300	300
Material loading capacity (mL)	1200 or 1800	900	1200 or 1800	900
Manifold	/	/	8 pieces	8 pieces
USB interface	Y	Y	Y	Y
Drying chamber (standard)	Transparent acrylic			
Vacuum pump	Standard model: 2XZ-2**; Speed: 2L/S			
Control system	Microprocessor, touch screen			
Ultimate vacuum (Pa)	Economic: 1 Classic and Premium : 0.6 for -60°C/0.3 for -80°C			
Noise (dB)	<66			
Electrical requirement				
Electrical voltage	220V			
Electrical frequency	50Hz, 60Hz			
Power (Kw)	0.95 or 1.5			
Size information				
Condenser chamber dimension (φ×Hmm)	217×250			
Sample tray dimension (φ×Hmm)	200×20			
Sample shelf dimension (φ×Hmm)	210×365	234×518	210×365	234×518
Sample Shelf distance average (Hmm)	76 or 50***	70	76 or 50***	70
Host size (WxDxHmm)	480×610×905			
Vacuum hood dimension (upperφ/lowerφ×Hmm)	260/240×450			
Exterior dimension (WxDxHmm)	480×610×1355	480×610×1415	480×610×1355	480×610×1415
Host net weight (Kg)	70 or 83****			
Package information				
Host package (WxDxHmm)	730×600×1180			
Vacuum hood package (WxDxHmm)	410×410×640			
Vacuum pump package (WxDxHmm)	220×580×370			
Weight (Kg)	135 or 155****			

*Optional 6 shelves with additional cost, with 0.18m² freeze drying area, and 1800ml material loading capacity.

**For customized vacuum pump, please see page 19 optional accessories for more details.

***50 mm for 6 shelves.

****70kg /135kg for freeze dryer (-60°C), 83kg /155kg for freeze dryer (-80°C).

Laboratory Scale - Console

Classic INOFD-18SU; INOFD-18TU; INOFD-18PU; INOFD-18PTU

Premium INOFD-18SUP; INOFD-18TUP; INOFD-18PUP; INOFD-18PTUP



INOFD-18SU
INOFD-18SUP



INOFD-18TU
INOFD-18TUP



INOFD-18PU
INOFD-18PUP



INOFD-18PTU
INOFD-18PTUP

Technical Parameter

Model	INOFD-18SU INOFD-18SUP	INOFD-18TU INOFD-18TUP	INOFD-18PU INOFD-18PUP	INOFD-18PTU INOFD-18PTUP
Basic information				
Type	Standard chamber	Stoppering chamber	Standard chamber with 8 port manifold	Stoppering chamber with 8 port manifold
Final condenser temp (°C)	-60 or -80	-60 or -80	-60 or -80	-60 or -80
Vacuum degree (Pa)	<10	<10	<10	<10
Condenser volume (L)	28	28	28	28
Freeze drying area (m ²)	0.18 or 0.27	0.135	0.18 or 0.27	0.135
Water condenser capacity (Kg/24h)	6	6	6	6
Qty of shelf	4 or 6*	3	4 or 6*	3
Material loading capacity/shelf (mL)	450	450	450	450
Material loading capacity (mL)	1800 or 2700	1350	1800 or 2700	1350
Manifold	/	/	8 pieces	8 pieces
USB interface	Y	Y	Y	Y
Drying chamber (standard)	Transparent acrylic			
Vacuum pump	Standard model: 2XZ-4**; Speed: 2.2L/S			
Control system	Microprocessor, touch screen			
Ultimate vacuum (Pa)	Economic: 1 Classic and Premium : 0.6 for -60 °C /0.3 for -80 °C			
Noise (dB)	<66			
Electrical requirement				
Electrical voltage	220V			
Electrical frequency	50Hz, 60Hz			
Power(Kw)	1.2 or 1.7			
Size information				
Condenser chamber dimension (φ×Hmm)	300×420			
Sample tray dimension (φ×Hmm)	240×20			
Sample shelf dimension (φ×Hmm)	250×391	276×518	250×391	276×518
Sample Shelf distance average (Hmm)	81 or 51***	71	81 or 51***	71
Host size (WxDxHmm)	567×710×940			
Vacuum hood dimension (upperφ/lowerφ×Hmm)	300×450			
Exterior dimension (WxDxHmm)	560×710×1390	560×710×1450	560×710×1390	560×710×1450
Host net weight (Kg)	85 or 100****			
Package information				
Host package (WxDxHmm)	790×630×1180			
Vacuum hood package (WxDxHmm)	410×410×640			
Vacuum pump package (WxDxHmm)	220×580×370			
Weight (Kg)	150 or 170****			







*Optional 6 shelves with additional cost, with 0.18m² freeze drying area, and 1800ml material loading capacity.







**For customized vacuum pump, please see page 19 optional accessories for more details.

***50 mm for 6 shelves.

****85kg /150kg for freeze dryer (-60 °C), 100kg /170kg for freeze dryer (-80 °C).

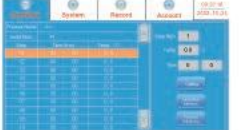
Model Selection

Series	Classic	Premium
Control system		
Controller	PLC controller	
Authority levels	Three-level account password authority management 	
Alarm system		
Alarm method	Buzzer alarm + screen text prompt 	
Refrigeration system monitoring alarm	YES 	
Vacuum pump maintenance alarm	The maintenance time of the vacuum pump can be independently set and modified 	
Vacuum Degree alarm	NO	YES 
Data tracking		
Historical data	Large-capacity storage module can store more than 1000 freeze-drying curves and alarm records 	

Series	Classic	Premium
Vacuum system		
Vacuum gauge	Stable and reliable Accuracy 0.01Pa 	
Ultimate vacuum (no load)	0.6Pa	
Vacuum pump protection function	Yes	
Vacuum pump protection temperature setting	YES Vacuum pump begins to work automatically when condenser chamber reached the setting temperature	
Vacuum degree control	NO	The required vacuum degree can be set and modified, so that the vacuum degree of the freeze dryer can work under the set value 
Customized setting of freeze-drying process	NO	40 programs can be set 
Structure		
Countertop Insulation Structure	Unique bridge design on the countertop of condenser chamber 	
Drain and inflation port	Drain and charge port separated, independent drain valve and charge valve 	
Nitrogen filling valve	Standard	Standard
Components testing		
Manual test	Manual test function of main functional components, which can realize the self-checking of every single component 	
Electric heating		
Shelf electric heating function	Optional (12,18)	Standard (12,18)
Heating defrost function for condenser chamber	Optional	Optional

Pilot Scale - Benchtop



INOFD-10TSS

INOFD-10TSP

INOFD-10TST

INOFD-10TSPT

Pilot Scale - Floor Stand



INOFD-20S
INOFD-30S
INOFD-50S
INOFD-100S

INOFD-20T
INOFD-30T
INOFD-50T
INOFD-100T

INOFD-200S

INOFD-200T

Technical Parameter

Model	INOFD-10TSS	INOFD-10TSP	INOFD-10TST	INOFD-10TSPT
Basic information				
Type	Standard chamber	4 port manifold	Stoppering chamber	Stoppering chamber with 4 port manifold
Final condenser temp (°C)	-88			
Shelf temp (°C)	-60~+70			
Temperature uniformity (°C)	±1			
Vacuum degree (Pa)	≤0.1			
Condenser volume (L)	11			
Freeze drying area (m²)	0.1			
Condensing capacity (Kg/24h)	3			
Qty of shelf	1			
Drying chamber volume (L)	40			
Material loading capacity (mL)	3000			
Penicillin bottle φ22	216			
Penicillin bottle φ16	400			
Penicillin bottle φ12	726			
Manifold	/	4 pieces	/	4 pieces
USB interface	Y			
Drying chamber (standard)	Transparent acrylic			
Vacuum pump	Standard model: VRD-8*			
Control system	Microprocessor, touch screen			
Electrical requirement				
Electrical voltage	220V			
Electrical frequency	50Hz, 60Hz			
Power (Kw)	2.3			
Size information				
Condenser chamber dimension (φxHmm)	300x438x320			
Shelf specification (WxDxHmm)	270x400x150		270x400x120	
Exterior dimension (WxDxHmm)	820x695x600/995		820x695x875/1075	
Package information				
Host package (WxDxHmm)	940x840x990			
Vacuum pump package (WxDxHmm)	600x230x300			
Weight (Kg)	157	165	165	170

*For customized vacuum pump, please see page 19 optional accessories for more details.

Technical Parameter

Model	INOFD-20S	INOFD-20T	INOFD-30S	INOFD-30T	INOFD-50S
Basic information					
Type	Standard	Top-press	Standard	Top-press	Standard
Shelf temp (°C)	-50~70	-50~70	-50~70	-50~70	-50~70
Final condenser temp (°C)	-80	-80	-80	-80	-80
Vacuum degree (Pa)	<10	<10	<10	<10	<10
Condenser volume (L)	13	13	13	13	17
Freeze drying area (m²)	0.24	0.24	0.36	0.36	0.5
Condenser capacity (Kg/24h)	6.5	6.5	6.5	6.5	10
Distance between shelves (mm)	145	145	90	90	90
Liquid material loading capacity (L)	4.5	4.5	7	7	10
Temperature uniformity (°C)	±1	±1	±1	±1	±1
Cooling mode	Air cooling	Air cooling	Air cooling	Air cooling	Air cooling
Heating defrost function for condenser chamber	Y	Y	Y	Y	Y
Cap seal method	N	Hydraulic pressure	N	Hydraulic pressure	N
Vacuum pump	Standard model: BSV-30; Speed: 8.3L/S				
Ultimate vacuum	≤10	≤10	≤10	≤10	≤10
Noise(dB)	<80	<80	<80	<80	<80
Electrical requirement					
Electrical voltage	220V or 380V		380V		380V
Electrical frequency	50Hz, 60Hz		50Hz, 60Hz		50Hz, 60Hz
Power(Kw)	3	3.5	3	3.5	6
Size information					
Condenser chamber dimension (φxHmm)	240x307		240x307		248x356
Drying room dimension (WxDxHmm)	470x495x415		470x495x415		470x558x550
Exterior dimension (WxDxHmm)	1339x932x1319	1339x932x1601	1339x932x1319	1339x932x1601	1337x1015x1454
Shelf specification (LxWxHmm)	300x400x20		395x335x15		300x450x20
Qty of shelf	2+1	2+1	3+1	3+1	4+1
Penicillin bottle φ22	468	468	702	702	1040
Penicillin bottle φ16	864	864	1296	1296	1944
Penicillin bottle φ12	1584	1584	2376	2376	3456
Host net weight (Kg)	380	425	400	445	520
Package information					
Host package (WxDxHmm)	1490x1140x1660				1660x1260x1710
Vacuum pump package (WxDxHmm)	850x330x450				850x330x450
Weight (Kg)	550	600	580	630	690

Technical Parameter

Model	INOFD-50T	INOFD-100S	INOFD-100T	INOFD-200S	INOFD-200T
Basic information					
Type	Top-press	Standard	Top-press	Standard	Top-press
Shelf temp (°C)	-50~70	-50~70	-50~70	-50~70	-50~70
Final condenser temp (°C)	-80	-80	-80	-80	-80
Vacuum degree (Pa)	<10	<10	<10	<10	<10
Condenser volume (L)	17	35	35	90	90
Freeze drying area (m²)	0.5	1	1	2	2
Condenser capacity (Kg/24h)	10	15	15	40	40
Distance between shelves (mm)	90	90	90	100	100
Liquid material loading capacity (L)	10	20	20	40	40
Temperature uniformity (°C)	±1	±1	±1	±1	±1
Cooling mode	Air cooling	Air cooling	Air cooling	Air cooling	Air cooling
Heating defrost function for condenser chamber	Y	Y	Y	Y	Y
Cap seal method	Hydraulic pressure	N	Hydraulic pressure	N	Hydraulic pressure
Vacuum pump	Standard model: BSV-30; Speed: 8.3L/S	Standard model: BSV-60; Speed: 16.7L/S			
Ultimate vacuum	≤10	≤10	≤10	≤10	≤10
Noise(dB)	<80	<80	<80	<80	<80
Electrical requirement					
Electrical voltage	380V	380V		380V	
Electrical frequency	50Hz, 60Hz	50Hz, 60Hz		50Hz, 60Hz	
Power(Kw)	6.5	9.5	10	14.5	15
Size information					
Condenser chamber dimension (φxHmm)	248x356	300x507		360x910	
Drying room dimension (WxDxHmm)	470x558x550	640x695x550		680x895x820	
Exterior dimension (WxDxHmm)	1337x1015x1754	1633x1027x1612	1633x1027x1912	1260x3710x2076	1260x3710x2476
Shelf specification (LxWxHmm)	300x450x20	550x480x20		600x600x20	
Qty of shelf	4+1	4+1	4+1	6+1	6+1
Penicillin bottle φ22	1040	2016	2016	4100	4100
Penicillin bottle φ16	1944	3944	3944	7800	7800
Penicillin bottle φ12	3456	7020	7020	14400	14400
Host net weight (Kg)	565	655	700	2000	2050
Package information					
Host package (WxDxHmm)	1660x1260x1710	1960x1340x1860		1600x1550x2400 1600x2050x2400	
Vacuum pump package (WxDxHmm)	850x330x450	1010x340x510		Vacuum pumps are not individually packaged	
Weight (Kg)	740	900	950	2300	2400

Optional Accessories

• Vacuum Pump

Model	Description
2XZ-2	Made in China, standard vacuum pump, 2L/S for 10,12 type
2XZ-4	Made in China, standard vacuum pump, 4L/S for 18 type
VRD-8	Made in China, optional vacuum pump, 2.2L/S, for 10,12 and 18 type
D8C	2.2L/S(8m ³ /h), Leybold Germany, optional for models, 10 and 12 (lead time 4-6 months)
D16C	2.6L/S(17m ³ /h) Leybold Germany, optional for models,18 (lead time 4-6 months)
BSV-30	Made in China, standard vacuum pump, 8.3L/S for 20, 30, 50 type
BSV-60	Made in China, standard vacuum pump, 16.7L/S for 100, 200 type
Oil for vacuum pump	1 L/barrel for standard vacuum pump, 2XZ-2 and 2XZ-4
Oil-gas filter (air exhaust)	For vacuum pump series 10,12,18
Dust filter/ Water vapor filter (front)	For vacuum pump series 10,12,18



Dust filter



Oil-gas filter



Water vapor filter

Model	2XZ-2	2XZ-4	VRD-8	D8C	D16C	BSV-30	BSV-60	
Speed(L/S)	2	4	2.2	2.2	2.6	8.3	16.7	
Ultimate pressure (Pa)	Partial pressure	$\leq 6 \times 10^{-2}$	$\leq 6 \times 10^{-2}$	$\leq 5 \times 10^{-2}$	$\leq 4 \times 10^{-4}$	$\leq 4 \times 10^{-4}$	5×10^{-1}	5×10^{-1}
	Full pressure	≤ 1.33	≤ 1.33	$\leq 5 \times 10^{-1}$	$\leq 3 \times 10^{-3}$	$\leq 3 \times 10^{-3}$	/	/
Working voltage (V)	220/380	220/380	220/380	220/380	220/380	380	380	
Motor power (Kw)	0.37	0.55	0.4/0.37	0.55	0.75/0.55	1.1	2.2	
Inlet diameter (outer diameter)	KF-25	KF-25	KF-16/25	KF-25	KF-25	VG40	VG50	
Noise (dB)	66	66	52	54	56	70	70	
Oil capacity (L)	0.8	1	0.6-1.0	1.1	1.5	1.2-2.8	2.5-4.2	
Dimensions (mm)	480×140×250	520×140×250	440×144×217	475×170×272	560×170×272	210×606×346	260×736×366	
Gross weight/Net weight(Kg)	22/20	24/22	23/21	32/30	34/32	65/63	89/87	



2XZ-2/2XZ-4



VRD-8



D8C/D16C



BSV-30/BSV-60

NO.	Item	Model	Image	Description
1	Stainless steel drying rack price calculate based on 5 type	20 ports		20 adapters and 20 flasks included, for organic solvents stainless steel manifold interface and pole
2		24 ports		24 adapters included, for ampoule flask stainless steel manifold interface and pole
3	Adapters and manifold flasks	Adapter 01		For ampoule flask
		Adapter 02		For eggplant shaped flasks
		100mL		Eggplant shaped flask
		250mL		
		500mL		
		1000mL		
		Adapter 03		For wide mouthed flask
800mL		Wide mouthed flask		
Freeze flask P type application		8 port adapters and 8 manifold wide mouthed flasks		
4	Electric heating	Shelf electric heating function		For shelf of series 12 and 18 (expect UP models as standard configuration)
		Heating defrost function for condenser chamber		For series 10, 12 and 18
5	Nitrogen filling valve	Nitrogen filling valve		Connected to nitrogen or inert gas cylinders for economic models 10,12,18
6	Upgraded Temp. of condenser chamber	-80℃		For series 12 and 18