



GLASSWARE WASHER



Qingdao Innova Bio-Meditech Co., Ltd.

Add.: 1212, Building #5, No. 176 Jufeng Road, 266199, Qingdao, China

Tel.: +86 532 8789 0634

Email: info@innobiomed.com

Web: www.innovabiomed.com



Qingdao Innova Bio-Meditech Co., Ltd.

About us

Innova Bio-Meditech is one of the professional solution provider of laboratory and medical devices. Firmly committed to our mission of "sharing innovative bio-meditech solutions with the world", we are dedicated to innovation in the fields of Biology Project, Life Science, Pharmacy Industry and Medical Treatment.

Innova Bio-Meditech possesses a sound distribution and service network with business partners in North and Latin America, Europe, Africa and Asia-Pacific etc. We have built up a well established R&D, manufacture network with 3 centers in Beijing, Qingdao, and Shanghai. Inspired by the needs of our customers, we adopt advanced technologies and transform them into accessible innovation. This means constant effort and research, in order to more fully understand the developments of the market, INNOVA produce constantly upgraded product ranges by adding new products year after year.

The passion for science

Comprehensive solutions can be provided



Laboratory glassware washer

Applied to cleaning, disinfection and drying of various utensils in laboratories and production departments of pharmaceutical companies, disease control centers, scientific research institutes, food factories, chemical companies, electronic companies, etc.

Heavy duty glassware washer

Applied to various large glassware, components in filling line and tablet press, animal cages, drinking bottles, feed boxes and other equipment, etc.



INNOVA glassware washer is designed to provide unmatched flexibility, excellent cleaning and drying efficiency. When combined with especially formulated chemistries and global service offering, INNOVA unique certified cleaning process provides a higher level of assurance that expected cleaning results are achieved.



Stainless steel interior, exterior, racks and inserts withstand heavy use and reduce corrosion and contaminant build-up. Internal components such as pumps and seals are laboratory-grade, engineered for long life.

Interior work area: #316L stainless steel

Exterior body : #304 stainless steel

Washer trolley: #304 stainless steel and optional for #316L stainless steel

Product diagram



- 1 Touch screen controller
- 2 Emergency button
- 3 USB port
- 4 Cleaning rack
- 5 Double-layer glass door
- 6 Peristaltic pump
- 7 Level probe
- 8 Detergent bottle
- 9 Drain
- 10 Pure water inlet
- 11 Tap water inlet
- 12 Castors with feet

Wide capacity range to meet individual needs

- Single door and optional double door pass through
- Benchtop and floorstand glassware washer with/without drying function
- Over 40 standard cleaning racks, which can meet 90% of users' needs, and customized racks also available

◀ **Tabletop
Eco dry***



INOGW -80
80L, 1 layer



INOGW -120
120L, 1 layer

◀ **Economic model
Eco dry***



INOGW -200E
200L, 2 layers



INOGW -200
200L, 2 layers



INOGW -220
220L, 2 layers



INOGW -320
320L, 3 layers

◀ **Double auto sash door**



INOGW -420
420L, 2 layers

* Drying with use of residual heat

Building:

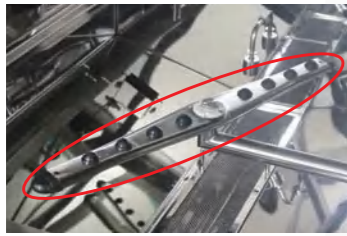

Specially designed spray arm, and sector water curtain spray to ensure 360-degree cleaning without dead ends.

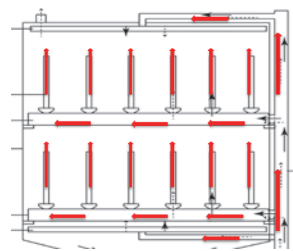

Multi-layer washing racks with parallel water intake independently to avoid pressure difference between layers. The central water distribution ensures that the nozzles spray water evenly.

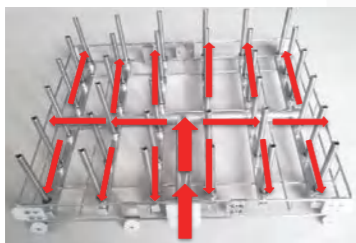

The nozzles of cleaning rack are distributed in parallel and equidistant, which effectively increases the cleaning capacity. The interface is made of Teflon material to avoid cleaning pollution.



Two-way water source inlet design, and automatic control by solenoid valve. Different water sources can be selected in the cleaning process to ensure cleaning quality.



With overflow protection, if there is too much water in cleaning chamber, the program will be stopped after alarm, and the water will be automatically drained at the same time.



The cleaning aids are automatically and quantitatively added by peristaltic pump.

Core Parts:



The cleaning agent shortage reminder function, which can remind staff to add cleaning agent in time.



There is flow meter for water intake, and influent water volume is displayed digitally in real time.



Circulating pump is imported from Europe, with large water volume and customized structure to achieve the best matching of cleaning pressure and water flow.



Pure water inlet adopts built-in booster pump, which can directly inhale pure water without external booster.

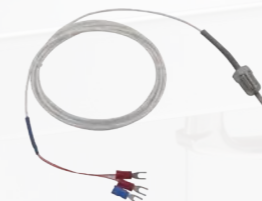

Double monitoring of cleaning temperature to ensure accurate temperature.



Independent drainage pump, with the water seal design of the drainage pipeline to prevent the backflow of sewage.

Microprocessor Control System

7" color LCD touch screen display, microprocessor with PLC system which is various of programmable washer cycles, detergent volume etc. User programmable with 99 storable programs and definable. All significant parameters can be set. These include: execution times, operating temperatures, quantity of additives, water source, influent water volume, etc. The LCD screen displays the current running steps and working parameters in real time. Access to the control operations is protected by a system of 3 levels password. It also with power-off memory function.

Cleaning Program:

INOGW120-320: 12 pre-set programs, which covers cleaning of common contaminants. Also with 99 PLC free programming. Users can define different washing steps such as Pre-Wash, Wash, Running Water, Acid Rinse, Neutralized Washing, Hot Water Washing, Drying etc. in one washing cycle. It can also adjust water temperature, washing time, volume of detergent, drying temperature and drying time in related washing step.

INOGW80: Full-featured, and include standard wash, enhanced wash, quick wash three modules. Steps and parameters can be edited.

INOGW420: Full-featured, and include 6 standard programs. Parameters can be edited, such as water volume, temperature, etc.



System Wash Levels

- 1 to 3 levels according to the models;
- Rack actuated via automatic manifold connections when door is closed;
- Rack accessories independent and easily removable for use on all levels;
- Cleaning racks are universal for all levels, and the cleaning racks of INOGW-120, 200, 220, and 320 can be used in common with each other;
- Users can only use the lower cleaning rack, and the upper or middle racks can be removed to facilitate cleaning of utensils with different heights.

Spray System

- Two rotary spray arms are located top of and bottom of chamber;
- Rotary sprayer made of # 4 sanitary high-grade 304L stainless steel;
- Easily disassembled for cleaning and maintenance.

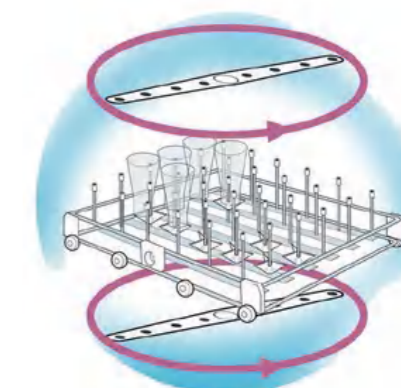

Monitoring System

- Audible and visual alarms provide quality control for each wash cycle water level sensors;
- Two independent sensors control chamber water level and prevent overflow.

Water Injection System

- Two water inlets controlled by electromagnetic valve, users can choose the tap water and pure water in wash and rinse phase. Washer trolley can connect the water and gas outlet automatically on each level which reduces the pressure loss and ensures wash and dry efficacy.

Dual Powerful Pumps

- One for washing and one for draining, reduce the potential risk of cross contamination between wash and drain water;
- Powerful pump recirculates water at a high rate to dislodge dried contaminants for thorough cleaning;
- Drain pump is associated with water seal drainage pipeline design avoid polluted water backflow.

Filter System

- Two stainless steel filters protect recirculation and drain pumps from debris;
- Filters easily removed for cleaning;
- Filters on all incoming water;
- Filters on air intakes.

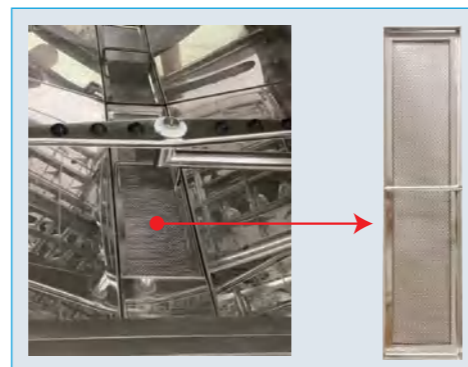

Dual Peristaltic Pumps

(Detergent & Neutraliser)

- Disinfection effectiveness mainly depends on the correct performance of the washing phases and the neutralization of the treated material. Innova washers are with two peristaltic pumps dedicated to dispensing the alkaline detergent during the cleaning phase and the acid neutralizer during the neutralization phase respectively.

Automatic Detergent Dispenser

- A peristaltic pump are equipped with separate sensors which automatically draws a programmed amount of automatic washer liquid detergent during wash cycles;
- 360 rotary sprayed upper and lower wash arms with rotary speed monitor devices can distribute water and detergent more efficient.

Drop Down Door

- Counterbalanced for ease of operation;
- Ensures proper rack placement and connection to manifold;
- Manufactured of solid 304L stainless steel with safe double glass window (INOGW-80 and INOGW-200A: Foam SS door w/o glass window);
- Fully insulated to reduce heat loss and noise;
- Provides loading platform eliminating need for loading cart.



Washing & Drying Cycle

- Water flow
- Drying air flow

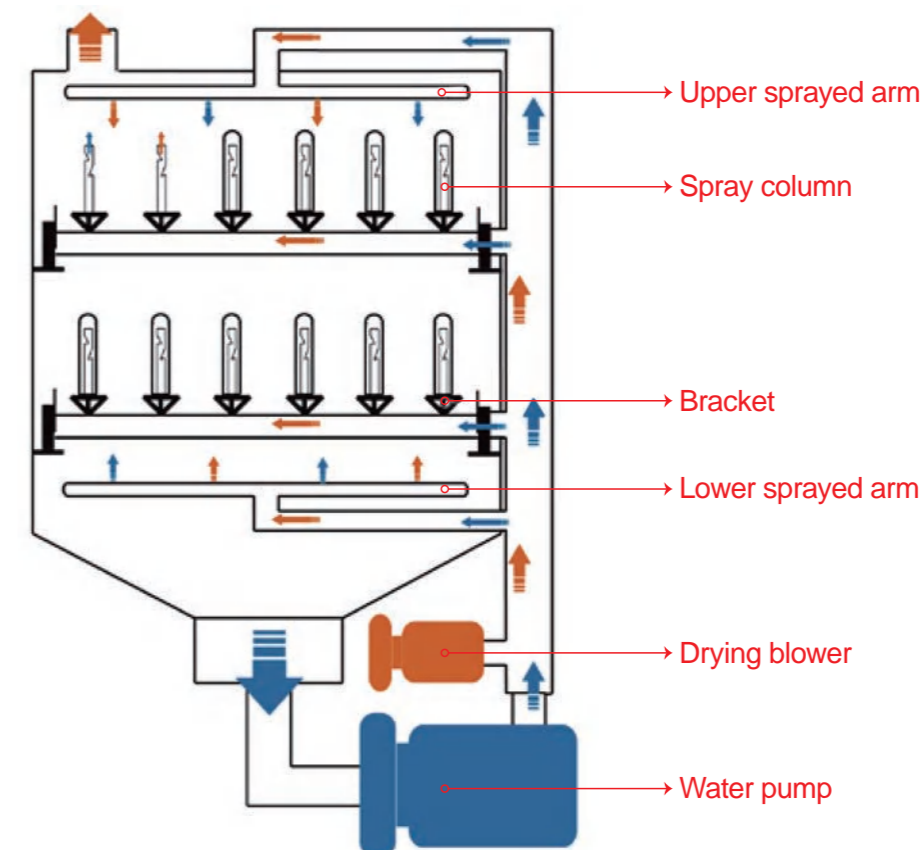

Drying System

The forced-air "Drying System" is a high-performance rapid drying system. The system, comprising an efficient hot air generator and a powerful fan, is directly managed by the programmer which allows both operating time and temperature parameters. The microprocessor PLC system assures intelligent management of the drying circuit by automatically adjusting fan speed (thereby reducing power consumption) according to the temperature measured in the washing chamber.



The efficient hot air temperature can be adjustable to 120 which enhanced washing, rinsing and sanitize glassware, and faster drying.

- Utensils and circulation pipeline are dried synchronously to avoid the growth of bacteria in the pipeline due to long-term humidity in the tube.
- Adopt HEPA high-efficiency air filter to ensure the cleanliness of dry air, and avoid secondary pollution of utensils by air.
- After drying, utensils can be quickly cooled to ensure that the users can safely remove the utensils for use.

Clean Air System

The air intake passes through a HEPA filter with at 99.7% (0.1um~0.3um) efficiency rating to washing chamber, top and bottom rotary sprayers and spray columns which avoid the air pollution and improve the dry efficacy. The drying system also effect on washing tube and avoid mould. If the HEPA filter is failed or broken, there is a alarm on it.



Steam Condenser

The steam condenser rapidly reduces the saturated steam from the washing water, especially during the thermal disinfection phases. This device eliminates the formation of condensation near the glassware washer and prevents humidity and smells from escaping into the air, especially in the versions positioned underneath worktops. In air-conditioned rooms moreover, limiting the dispersion of heat from the glassware washer reduces the work load of the air-conditioning system, considerably decreasing electricity consumption and unwanted temperature.

Reliability

- 1 . Microprocessor with PLC control system anti-EMI (electrical magnetic interface).
- 2 . 7" colorful touch screen is easy control and observation, and it display the work situation.
- 3 . Password protection with three levels can meet different management needs which block the authorized entry.
- 4 . Parameters setting memory for power failure, washer cycles is going on as soon as power comes back.
- 5 . Safety protection water temperature and dry air temperature, when the temperature exceed the setting, it will stop working.
- 6 . Safety lock with electromagnetic release to prevent door opening while it is in wash/dry cycle.
- 7 . Safety electrical system for circuit overload, short circuit, over current and leakage current.
- 8 . Safety emergency button for stop the unit in time.
- 9 . The door is anti-fall and anti-rebound design, and can be stopped at any angle from 0 to 90 degrees after opening.
- 10 . Alarm system: circulating pump overheated, water heating abnormal, air heating abnormal, cleaning agent shortage, door is not closed, water intake abnormal, overflow alarm, etc.
- 11 . USB port for exporting all the data relative to completed washing and disinfection programs.



Optional Accessories

● Water Conductivity Monitoring:

Sensor measures the level of dissolved inorganics such as calcium and ferrous ions in the tank water, providing validation of water cleanliness, hardness and rinsing thoroughness. Confirm that detergent, rinse aid and purified water have been properly dispensed.



● Printer:

The traceability of the washing and thermal disinfection cycles performed in professional glassware washers is required in order to check the operations have been successfully completed. The printer is an accessory which can provide a detailed report.







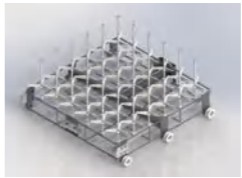

Technical Parameter

Items	Model	INOGW-80	INOGW-200E	INOGW-120	INOGW-200	INOGW-220	INOGW-320	INOGW-420	
Cleaning	Capacity (L)	80	200	120	200	220	320	420	
	Washer Load Level	1	2	1	2	2	3	2	
	Water Wash Power (kW)	0.25	0.4	0.4	0.75	0.75	1.5	1.5	
	Water Heater Power (kW)	3	3	5	5	5	15	5	15
	MAX. Power (kW)	3.5	4	6	6	6	16	7	17
	Water Consumption/Cycle (L)	8	15	17	18	20	22	25	
	Tank Internal Temperature (°C)	0~99	0~99	0~99	0~99	0~99	0~99	0~99	
	Water Supply Pressure (Mpa)	0.3~1.0							
	Peristaltic Pump for Cleaning Agent	2 independent pumps control detergent agent and neutralizing agent							
	Cleaning Agent Level Sensor	YES	YES	YES	YES	YES	YES	YES	YES
Washing Pump	Sweden 150L/min	Sweden 400L/min	Sweden 400L/min	Sweden 800L/min	Sweden 800L/min	Sweden 1000L/min	Sweden 1000L/min	Sweden 1000L/min	
Drying	Drying Function	NO	NO	YES	YES	YES	YES	YES	
	Steam Condenser	NO	NO	YES	YES	YES	YES	NO	
	Dry Power (kW)	NO	NO	3	3	3.6	3.6	3	
Control System and Traceability	Control System	4.3" color LCD touch screen display, microprocessor	7" color LCD touch screen display, microprocessor	7" color LCD touch screen display, microprocessor	7" color LCD touch screen display, microprocessor	7" color LCD touch screen display, microprocessor	7" color LCD touch screen display, microprocessor	6 standard programs (editable)	
	Cleaning Program	3 pre-set programs (editable)	12 pre-set programs (editable) + 99 PLC free programming	12 pre-set programs (editable) + 99 PLC free programming	12 pre-set programs (editable) + 99 PLC free programming	12 pre-set programs (editable) + 99 PLC free programming	12 pre-set programs (editable) + 99 PLC free programming	12 pre-set programs (editable) + 99 PLC free programming	
	Password Protection	3 levels password	3 levels password	3 levels password	3 levels password	3 levels password	3 levels password	3 levels password	
	Safety Emergency Button	NO	NO	YES	YES	YES	YES	YES	
	USB port	YES	YES	Optional	YES	YES	YES	NO	
	Integrated printer	NO	NO	Optional	Optional	Optional	Optional	Optional	
Online Monitor Performance of Washing	NO	NO	Optional	Optional	Optional	Optional	NO		
Dimensions & Weight	Chamber Dimension (W*D*H,mm)	470*462*422	526*542*645	600*629*539	600*629*679	600*629*754	600*629*915	688*700*703	
	Exterior Dimension (W*D*H,mm)	529*648*650	607*824*1050	980*740*870	990*740*1145	693*790*1825	693*790*1985	1110*900*2165	
	Package Dimension (W*D*H,mm)	650*780*850	720*980*1230	1110*940*1075	1110*940*1345	810*990*2015	810*990*2185	1230*1070*2290	
	Net Weight (Host only, kg)	65	125	169	193	220	237	370	
	Gross Weight (Host with rack, kg)	104	165	200	260	300	320	460	
Others	Door	Foam SS door	Foam SS door	Double-layered Glass Door	Double-layered Glass Door	Double-layered Glass Door	Double-layered Glass Door	Double-layered Glass Door 2 Doors,Electric	
	Safety Door Lock	YES	YES	YES	YES	YES	YES	YES	
	Built-in RO Water Pump	YES	YES	YES	YES	YES	YES	NO	
	Noise (dBa)	<50	<50	<50	<50	<55	<55	<60	
	Voltage (V/Hz)	220V~240V/50~60Hz	220V~240V/50~60Hz	220V~240V/50~60Hz	220V~240V/50~60Hz	220V~240V/50~60Hz 380V/50~60Hz	220V~240V/50~60Hz 380V/50~60Hz	220V~240V/50~60Hz 380V/50~60Hz	
	Certificate	CE+ISO9001	CE+ISO9001	CE+ISO9001	CE+ISO9001	CE+ISO9001	CE+ISO9001	CE+ISO9001	

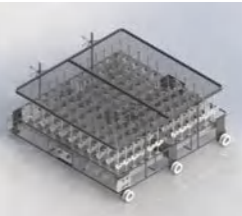





*SS=stainless steel

Accessories suit for INOGW-80

Product Name	Model	Image	Description
Injector rack	INIR36B		36 nos. of injectors, distance between injectors 6cm, only one layer can be placed
	INIR52B		52 nos. of injectors, distance between injectors 4.8cm, only one layer can be placed
	INIR126B		126 nos. of injectors, wash test tubes, liquid bottles, small volumetric flasks, etc, only one layer can be placed
	INIR6018B		Hybrid rack, 60 nos. of test tubes, liquid flasks + 18 nos. of beakers, volumetric flasks
Medical device rack	INBR02B		Double-layer integrated, 4 cleaning baskets, wash medical and forensic surgical instruments, knives and scissors
Test tube rack	INBR04B		Single layer with 4 nos. of 1/4 round cleaning baskets for cleaning test tubes
Culture dishes rack	INPDR9024B		Double-layer integrated, wash 12 nos. of culture dishes each layer, and total 24 culture dishes









- Washer racks are sold separately and can be customized
- Please consult for customized accessories

Accessories suit for INOGW-200E

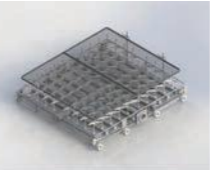
Product Name	Model	Image	Description
Beaker rack	INBR01A		Without injector, directly placed on the cleaning basket
Injector rack	INIR20A		20 nos. of injectors, distance between injectors 105mm
	INIR36A		36 nos. of injectors, distance between injectors 75mm
	INIR210A		210 nos. of injectors for autosamper vials
Combined rack	INIR8018A		80 nos. of injectors for autosamper vials, + 18 nos. of injectors for erlenmeyer flask
Pipette rack	INPR56A		56 nos. of pipettes, only one layer can be placed
Culture dishes rack (lower layer)	INPDR9044LA		Can wash 44 pieces at a time for culture dishe with a diameter of 90mm
Culture dishes rack (upper layer)	INPDR9044UA		Can wash 44 pieces at a time for culture dishe with a diameter of 90mm

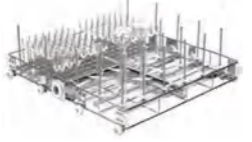







- Washer racks are sold separately and can be customized
- Please consult for customized accessories

Accessories suit for INOGW-120, 200, 220, 320, 420

Product Name	Model	Image	Description
Printer function	Optional for INOGW-120, 200, 220, 320, 420		Optional printer, can print cleaning process parameters
Real-time monitor system	Optional for INOGW-120, 200, 220, 320		Online monitor performance of washing through test conductivity of water
Small beaker rack plastic supporter suit for all models	INIR80		80 nos. of beaker rack (distance between injectors 56mm) ,which can wash small beakers, centrifuge tubes, volumetric flasks, etc.
Large beaker rack suit for all models	INBR01		Without injector, directly placed on the cleaning basket
Combined rack plastic supporter suit for all models	INIR11218		112 nos. of injectors (distance between injectors 30*30mm)+18 nos. of injectors (distance between injectors 90*86mm)
Combined rack suit for all models	INIR10072		100 nos. of pipettes + 72 nos. of autosamper vials, upright cleaning
Pipette rack suit for all models	INPR60		60 nos. of pipettes
	INPR6060		60 nos. of pipettes + 60 nos. of autosamper vials



- Washer racks are sold separately and can be customized
- Please consult for customized accessories

Accessories suit for INOGW-120, 200, 220, 320, 420

Product Name	Model	Image	Description
Injector rack plastic supporter suit for all models	INIR16		16 nos. of 1000ml erlenmeyer flasks, volumetric flasks etc. (distance between injectors 135*129mm)
	INIR20		20 nos. of 500ml erlenmeyer flasks, volumetric flasks etc. (distance between injectors 126*116mm)
	INIR36		36 nos. of 250ml erlenmeyer flasks, volumetric flasks, beakers, test tube etc. (distance between injectors 99*90mm)
	INIR60		60 nos. of erlenmeyer flasks, test tubes, measuring cylinders, beakers, etc. (distance between injectors 72*70mm)
	INIR120		120 nos. of injectors, can wash centrifuge tubes, test tubes and less than 50ml volumetric flasks, etc. (distance between injectors 53*48.5mm)
	INIR222		222 nos. of injectors, can wash autosampler vials, test tubes (distance between injectors 31*23mm)+ 1 set of basic basket (for wash caps of autosampler vial)
	INIR260		260 nos. of injectors, can wash autosampler vials, test tubes (distance between injectors 38*23mm)
Test tube rack suit for all models	INBR04		Without injector, with 4 cleaning baskets, can wash a large number of penicillin bottles, test tubes, etc.



- Washer racks are sold separately and can be customized
- Please consult for customized accessories

Accessories suit for INOGW-120, 200, 220, 320, 420

Product Name	Model	Image	Description
Culture dishes rack (upper layer) suit for all models	INPDR9070U		Can wash 70 pieces at a time for culture dishes with a diameter of 90mm
Culture dishes rack (lower layer) suit for all models	INPDR9070L		Can wash 70 pieces at a time for culture dishes with a diameter of 90mm
Three-layer culture dishes rack suit for INOGW-220, only one set can be placed	INPDR90210		Put it in the washing machine as a whole, which can wash 210 culture dishes at a time, and it can be used for INOGW-220
Four-layer culture dishes rack suit for INOGW-320, only one set can be placed	INPDR90280		Put it in the washing machine as a whole, which can wash 280 culture dishes at a time, and it can be used for INOGW-320
Graduated cylinder rack only one rack can be put inside suit for all models	INIR38		38 nos. of graduated cylinders
Rubber tube rack only one rack can be put inside Suit for all models (except INOGW120)	INRTR20		20 nos. of rubber tubes (3-5 m)
Absorption bottle rack only one rack can be put inside suit for all models (except INOGW120)	INAB40		40 nos. of absorption bottles
Medical cleaning basket	Standard DIN Basket		It can be placed on the INBR01 rack for cleaning vessel caps, medical scalpels, surgical scissors, etc. One INBR01 rack can hold two DIN baskets
Stainless steel supporter	Optional		Optional for injector racks, for big bottles, conventional rack with plastic supporter, this stainless steel supporter is for supplementary use

- Washer racks are sold separately and can be customized
- Please consult for customized accessories

Cleaning Solution

Product Name	Model	Capacity	Description
Cleaning solution combination (imported from Belgium RBS)	Detergent 	5L/barrel	Multi-purpose concentrated alkaline acid cleaner, made in Belgium, manufacturer is Chemical Products S.A., suitable for automatic cleaning
		2.5L/barrel	
	Neutraliser 	5L/barrel	
		2.5L/barrel	

Effective Cleaning Height

Model	Layers	Upper Layer (mm)	Middle Layer (mm)	Lower Layer (mm)
INOGW-320	1	/	/	686
	2	228	/	401
	3	228	227	117
INOGW-220	1	/	/	525
	2	242	/	228
INOGW-200	1	/	/	463
	2	177	/	232
INOGW-200E	1	/	/	439
	2	153	/	230
INOGW-120	1	/	/	345
INOGW-80	1	/	/	222

Glassware Washer Dimension Drawing (In mm)

INOGW-80
(Tabletop, without dryer)

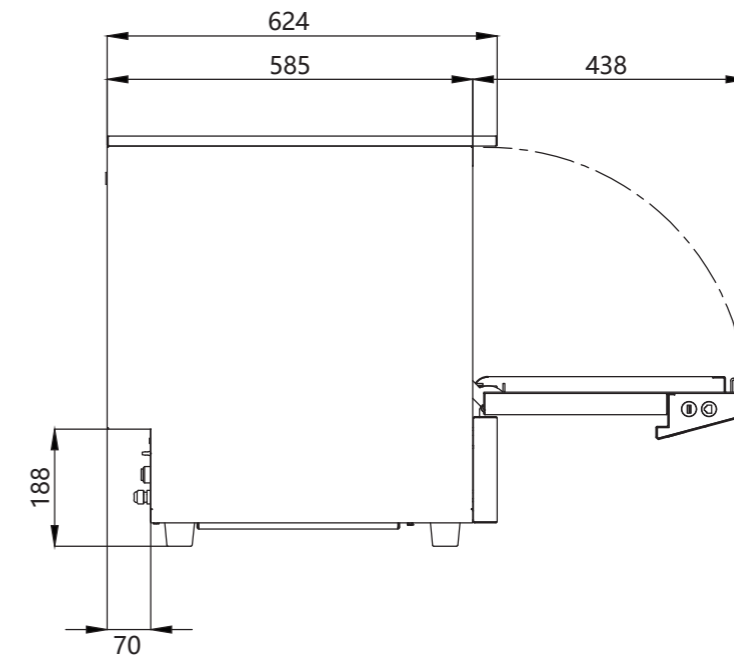
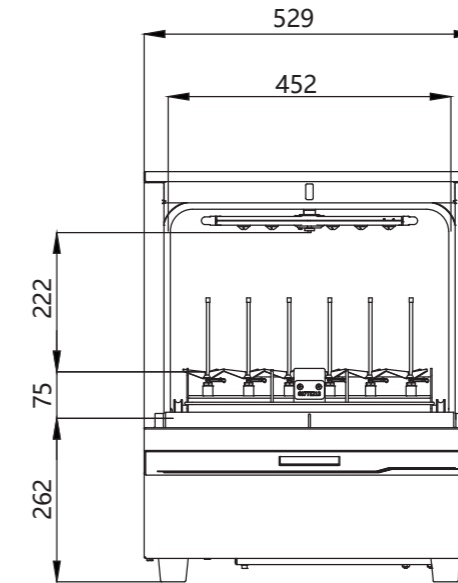

Glassware Washer Dimension Drawing

(In mm)

INOGW-120

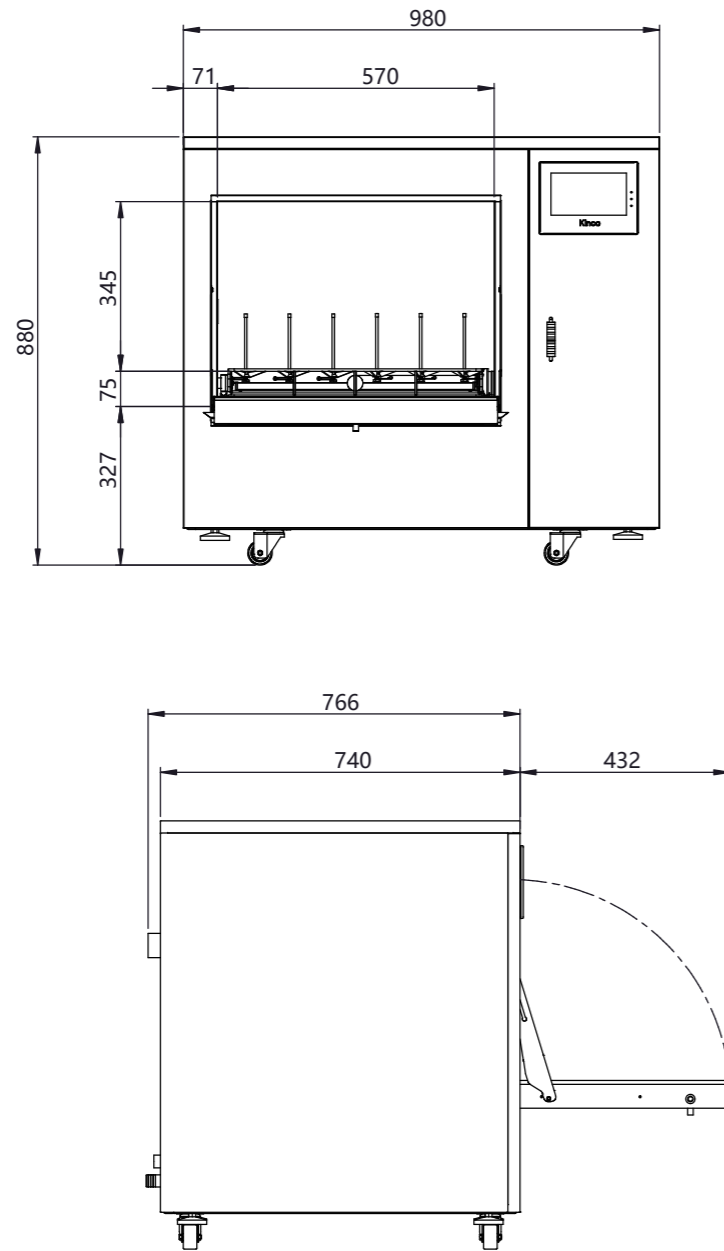

Glassware Washer Dimension Drawing

(In mm)

INOGW-200E

(Without dryer)

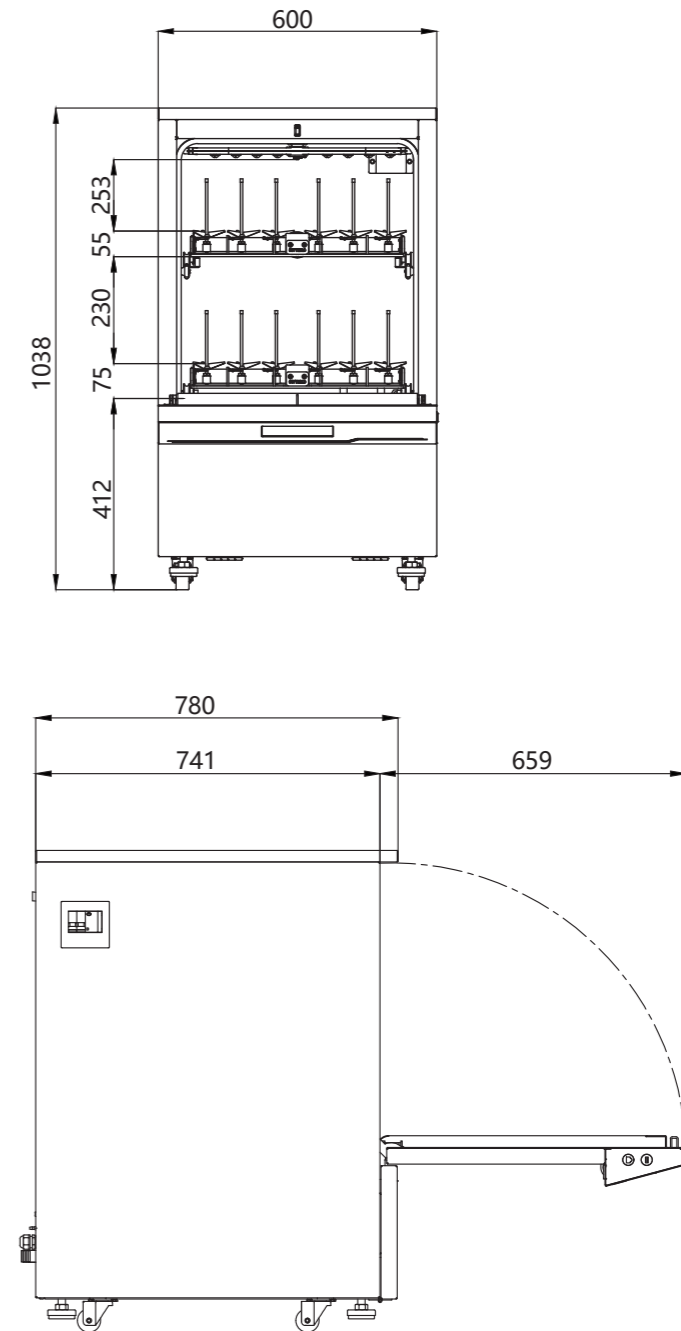

Glassware Washer Dimension Drawing

(In mm)

INOGW-200

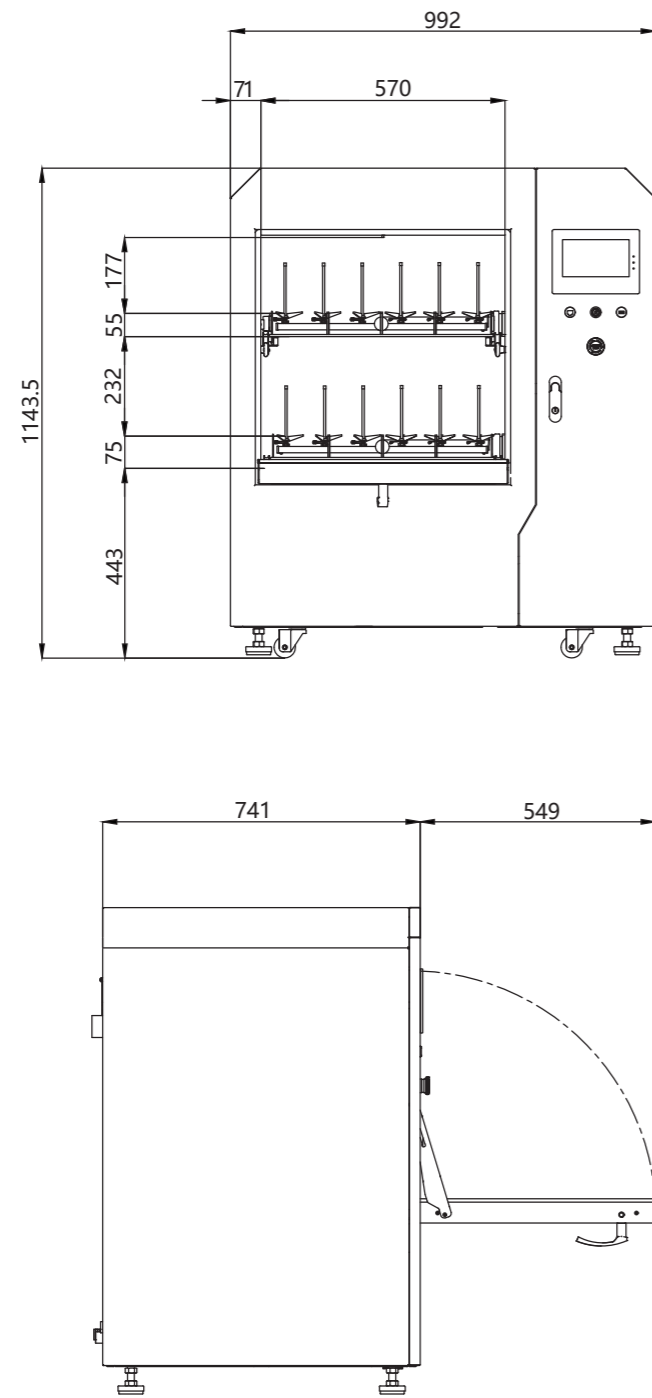

Glassware Washer Dimension Drawing

(In mm)

INOGW-220

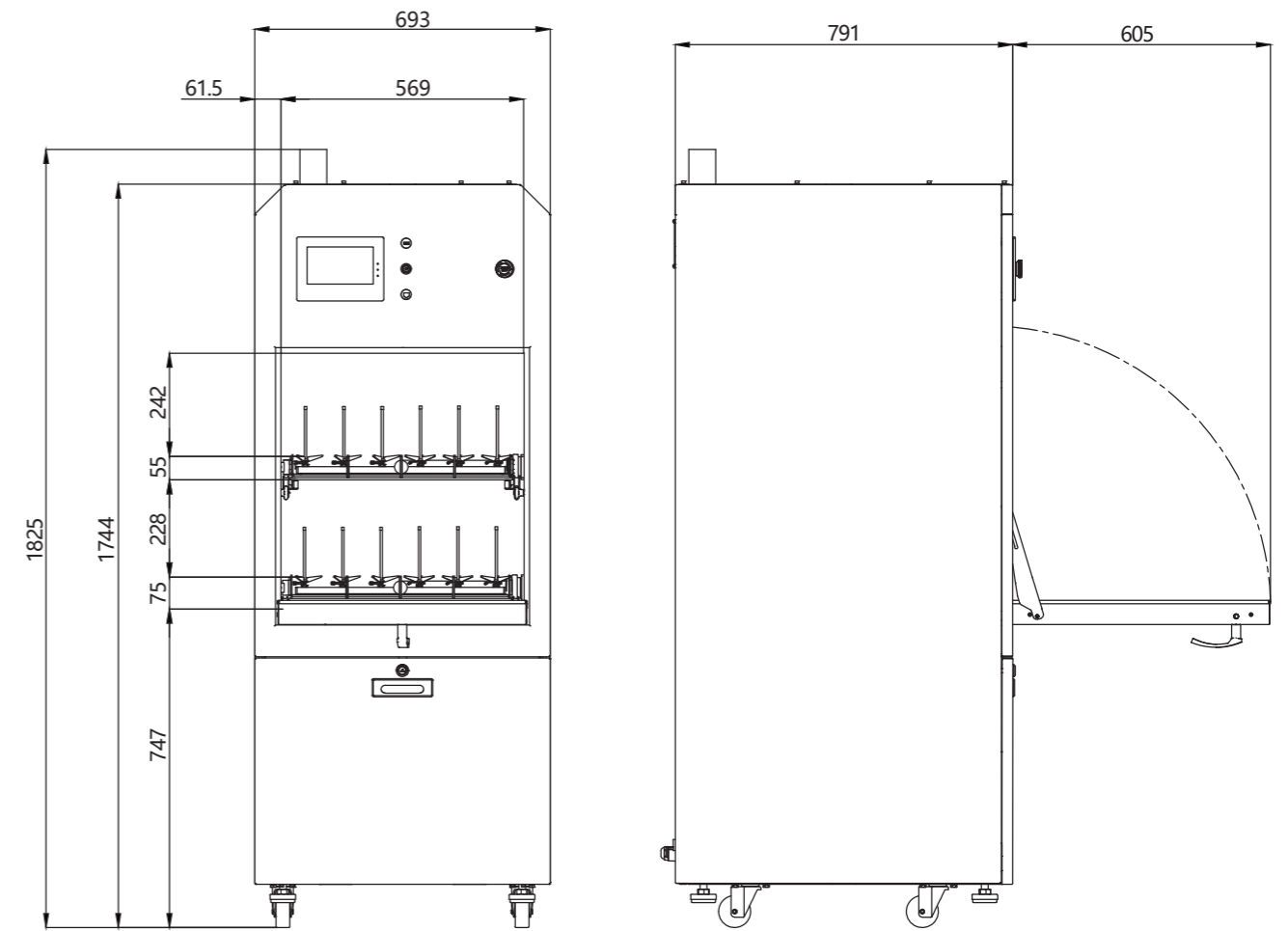

Glassware Washer Dimension Drawing

(In mm)

INOGW-320

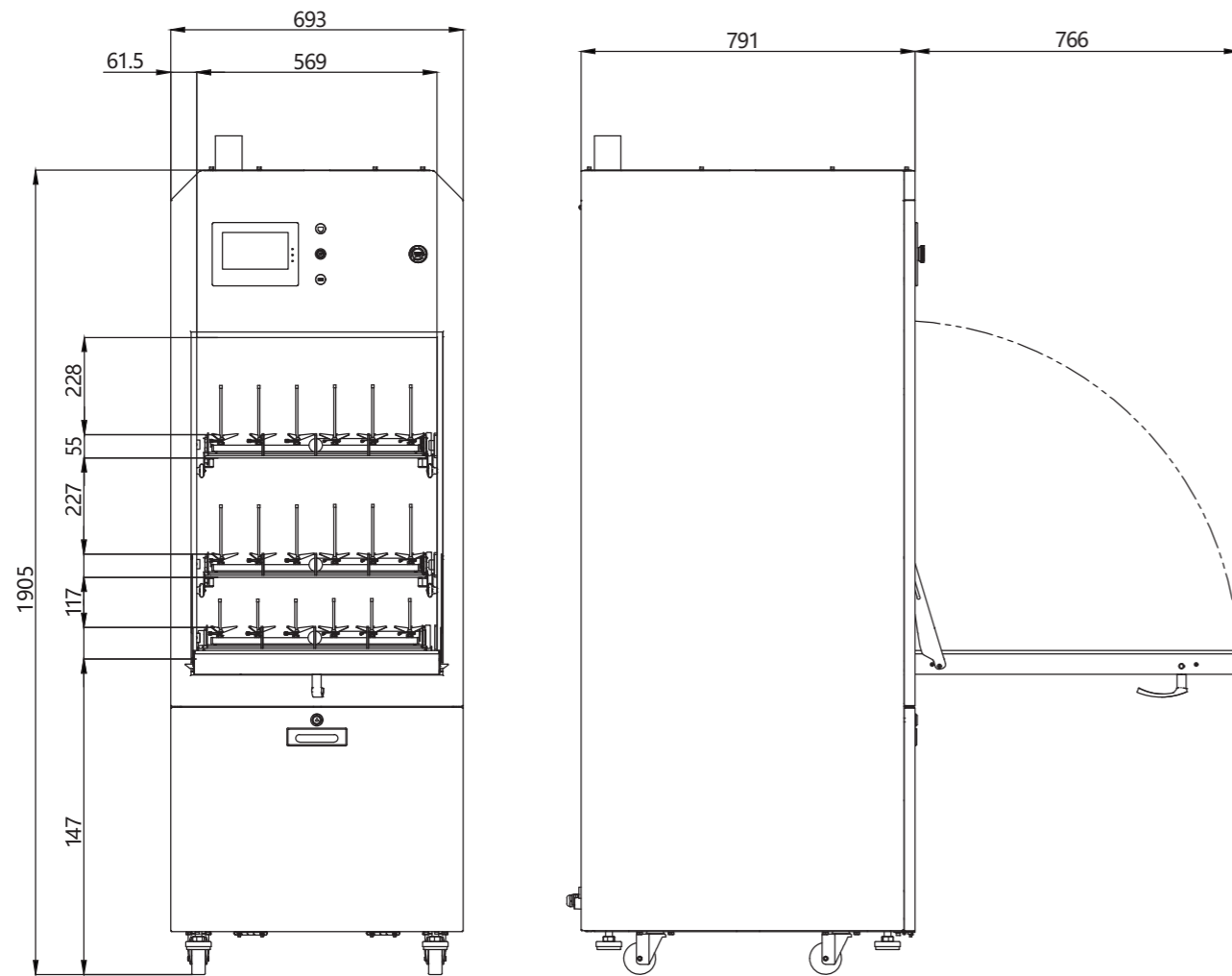

Glassware Washer Dimension Drawing

(In mm)

INOGW-420

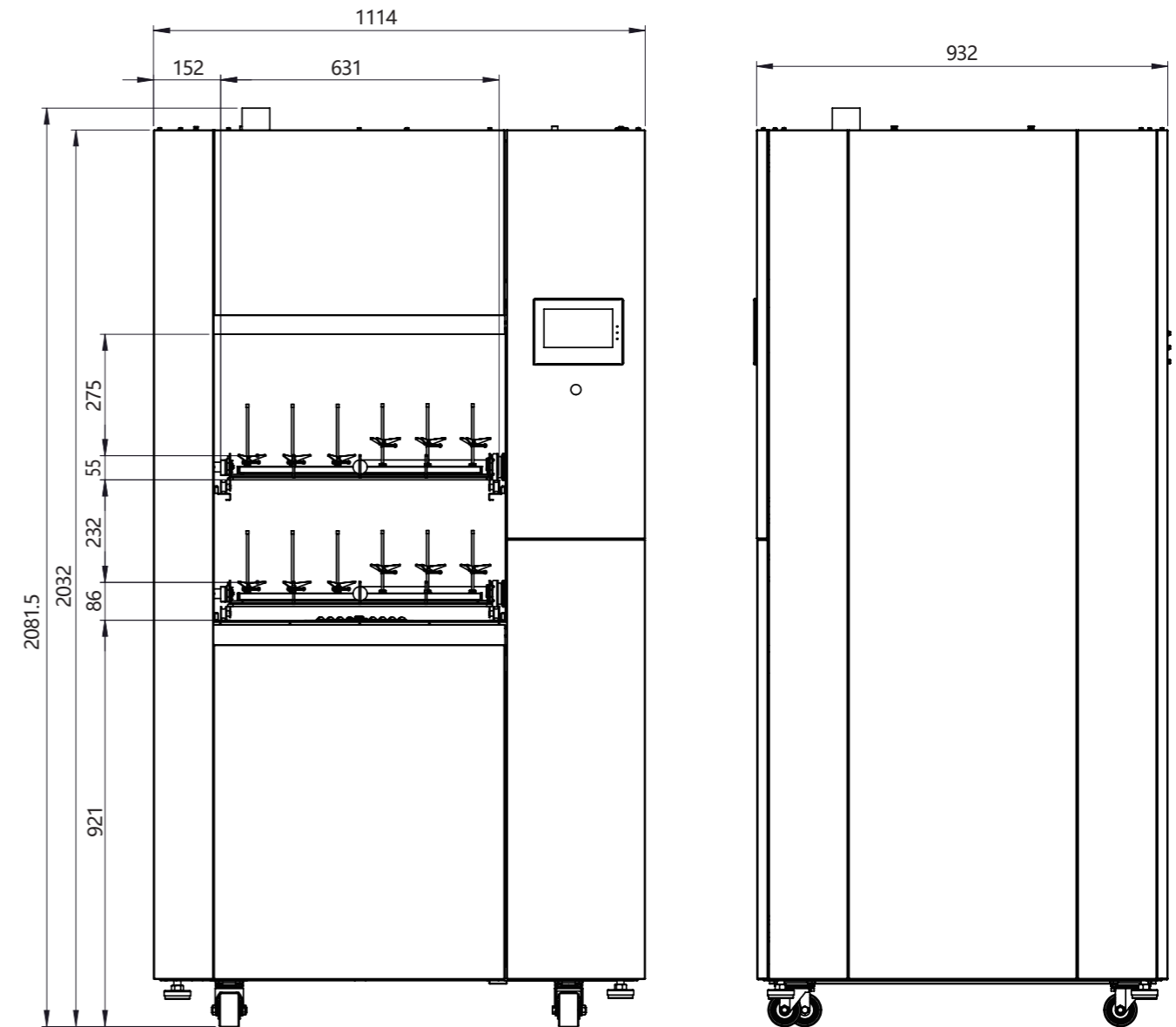

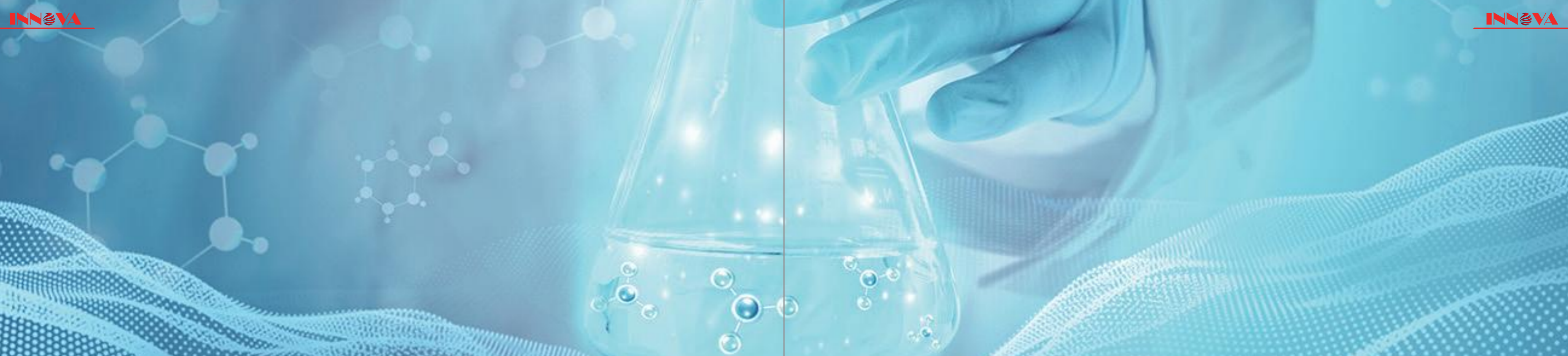

Heavy Duty Glassware Washer

Application

INNOVA heavy duty glassware washer is mainly used in the pharmaceuticals industry and food enterprises, to automatic cleaning, disinfection and drying various large glassware, components in filling line, components in tablet press, stainless steel filter shells, mixing barrels, bioreactors, PP barrels, connecting hoses, various connecting pipe fittings, etc. It can also be used for automatic cleaning of animal cages, drinking bottles, feed boxes and other equipment in experimental animal breeding.

Working Process

Example of basic cleaning process



The cleaning program can realize the free setting and storage of operating parameters, such as selection of influent water sources, cleaning temperature, operating time, cleaning agent dosage, cycle times, etc.

Drying System

- It consists of circulating fan, sanitary air heater and high efficiency air filter;
- When drying, hot air pass through the nozzles of the spray arms at the top and bottom of cleaning chamber, and the nozzles of cleaning rack quickly dries inner and outer surfaces of items with hot air;
- Adopt HEPA high-efficiency filter to ensure the cleanliness of dry air and avoid secondary pollution of clean items by air;
- After drying, utensils can be quickly cooled to ensure that users can safely remove the utensils for use.

Structural Design

- The cleaning chamber is made of 316L stainless steel, and the internal rounded structure has no dead corners for cleaning;
- All circulating pipelines and parts in contact with cleaning water are made of stainless steel and PTFE;
- The top of cleaning chamber can be equipped with internal lighting for easy visual inspection of cleaning conditions;
- Adopt hollow double-layer tempered glass door, which is heat-insulating and noise-reducing. Automatic lift door design is easy to operate. Moreover, the front and rear double door structure and manual opening structure also can be customized according to specific users needs;
- After the door is closed, the silicone rubber is automatically pressed by the independent stamping technology to ensure the airtightness and watertightness of the door body seal;
- Optional transfer cart for easy access to cleaning racks.

Cleaning System



- ① There are two rotating spray arms at the top and bottom of the cleaning chamber;
- ② Multi-layer washing racks with parallel water intake independently to ensure consistent pressure on each layer;
- ③ Standard with 2 water inlets (3 pcs optional), which can be connected to tap water and pure water (injection water) at the same time, and also can be customized according to requirements;
- ④ 7" or 10" LCD touch screen;
- ⑤ Emergency stop switch;
- ⑥ The cleaning aid is automatically and quantitatively added by peristaltic pump to ensure the cleaning effect;
- ⑦ Circulating pump is imported from Europe, and the amount of incoming water is monitored by flow meter, which to achieve the best matching of cleaning pressure and water flow.

Control System

- Siemens or equivalent quality PLC programmable control system, 7"/10" LCD touch screen;
- Equipped with 10 standard programs and 10 free programs, which can set various name modes such as Chinese, English, numbers, etc;
- With self-checking function of main components, which can realize the start and stop of individual components and check working status;
- Control system can prevent dust and moisture from entering, and control panel height conforms to human height for easy operation;
- With power-off memory function. If the power is temporarily cut off during the execution of the program, after the power is supplied again, the device can continue to work in the state of the program before the power-off.



Safety Protection

- The equipment is equipped with an emergency stop switch, in case of emergency, the power supply can be cut off immediately to stop running;
- The equipment has the function of real-time monitoring of water leakage and multi-layer filtering device;
- Automatic induction device for lift door operation, which can stop the movement immediately when there is an abnormality, so as to prevent accidents such as hand clamping, collision, extrusion caused by cleaning rack not in place or misoperation;
- The door cannot be opened while the device is running. It can only be opened after the whole process is over and the utensils has cooled down;
- The strong current distribution box and the weak current distribution box are respectively set up, which isolated from each other and with locks. The strong current distribution box is provided with a plurality of lockable transfer switches, which can be opened and closed independently to control the power on and off of each component circuit;
- Alarm function: circulating pump overheated, water heating abnormal, air heating abnormal, short of cleaning agent, water intake abnormal, and water overflow alarm, etc.

Audit Trail

- Three-level password authority management, which include super user authority, to realize adding other account names and passwords, and can set two permissions of "operator" and "administrator";
- More than 2000 cleaning records and over 2000 alarm records can be stored, which can be searched and viewed on the screen;
- Cleaning records and alarm information can be exported to U disk in PDF format; A printer can also be installed to print all related records in real time;
- Cleaning record content: including equipment number, equipment name, equipment model, program name, operator, start time, end time, cleaning steps (time, temperature, cleaning agent), fault name, etc;
- Traceability: all the information of equipment operation and parameter changes will be automatically recorded and stored by the system.

Technical Parameter

Model	INOPW- 400	INOPW-760	INOPW-1000	INOPW-1800
Exterior Dimension (W*D*H,mm)	1110*900*2165	1800*1000*2250	2000*1190*2250	2500*1540*2250
Capacity (L)	400	760	1000	1800
Control System	PLC / Siemens or equivalent			
Display	7" touch screen	10" touch screen		
Door Structure	Single door (double doors optional)			
Door Opening Method	Electric door (manual door optional)			
Circulating pump flowA(L/min)	1000	800	1000	1000
Circulating pump flowB(L/min)	/	800	1000	1500
Tank Internal Temperature (°C)	Rt - 93			
Water Heater Power (kW)	15	18	18	24
Drying temperature (°C)	Rt - 120			
Dry Power (kW)	3.6	6	11.25	15
Voltage (V/Hz)	380/50			

Cleaning Rack

- Adopt modular cleaning racks, and the suitable cleaning rack can be replaced according to the requirements of the cleaning items;
- According to different items, cleaning rack can be customized for users.

